

Metal oxide Semiconductor Field effect transistor: Basic structure, working of p channel MOSFET Enhancement type and study of output and transfer characteristics.

Reference: Donald A Neamen, "Semiconductor Physics and Devices", Tata McGraw Hill, 4th Edition, Boylestad, "Electronic devices and Circuit theory", Sedra and Smith, "Microelectronic Circuit Theory and applications".

METAL OXIDE SEMICONDUCTOR FIELD-EFFECT TRANSISTORS

MOSFET TOPIC BEGINS:

A metal oxide semiconductor field-effect transistor (MOSFET) is a unipolar device. The current flow in a MOSFET depends on one type of majority carrier (electrons or holes). The output current of MOSFETs is controlled by an electric field that depends on a gate control voltage. There are two types of MOSFETs: enhancement MOSFETs and depletion MOSFETs.

3.1.4 p-Channel Enhancement-Mode MOSFET

The complementary device of the n-channel enhancement-mode MOSFET is the p-channel enhancement-mode MOSFET.

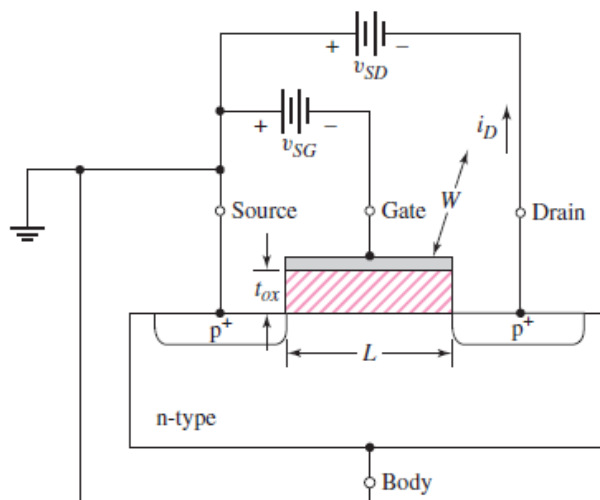

Figure 3.11 Cross section of p-channel enhancement-mode MOSFET. The device is cut off for $v_{SG} = 0$. The dimension W extends into the plane of the page.

Metal oxide Semiconductor Field effect transistor: Basic structure, working of p channel MOSFET Enhancement type and study of output and transfer characteristics.

P-channel MOSFET Enhancement type WORKING:

Transistor Structure

Figure 3.11 shows a simplified cross section of the p-channel enhancement-mode transistor. The substrate is now n-type and the source and drain areas are p-type. The channel length, channel width, and oxide thickness parameter definitions are the same as those for the NMOS device shown in Figure 3.5(a).

Basic Transistor Operation

The operation of the p-channel device is the same as that of the n-channel device, except the hole is the charge carrier rather than the electron. A negative gate bias is required to induce an inversion layer of holes in the channel region directly under the oxide. The threshold voltage for the p-channel device is denoted as V_{TP} .⁴ Since the threshold voltage is defined as the gate voltage required to induce the inversion layer, then $V_{TP} < 0$ for the p-channel enhancement-mode device.

Once the inversion layer has been created, the p-type source region is the source of the charge carrier so that holes flow from the source to the drain. A negative drain voltage is therefore required to induce an electric field in the channel forcing the holes to move from the source to the drain. The conventional current direction, then, for the PMOS transistor is into the source and out of the drain. The conventional current direction and voltage polarity for the PMOS device are reversed compared to the NMOS device.

Note in Figure 3.11 the reversal of the voltage subscripts. For $v_{SG} > 0$, the gate voltage is negative with respect to that at the source. Similarly, for $v_{SD} > 0$, the drain voltage is negative with respect to that at the source.

Metal oxide Semiconductor Field effect transistor: Basic structure, working of p channel MOSFET Enhancement type and study of output and transfer characteristics.

3.1.5 Ideal MOSFET Current–Voltage Characteristics—PMOS Device

The ideal current–voltage characteristics of the p-channel enhancement-mode device are essentially the same as the NMOS-E type device only difference is the drain current is out of the drain and v_{DS} is replaced by v_{SD} . The saturation point is given by $v_{SD}(\text{sat}) = v_{SG} + V_{TP}$.

Table 5.2 Regions of Operation of the Enhancement PMOS Transistor

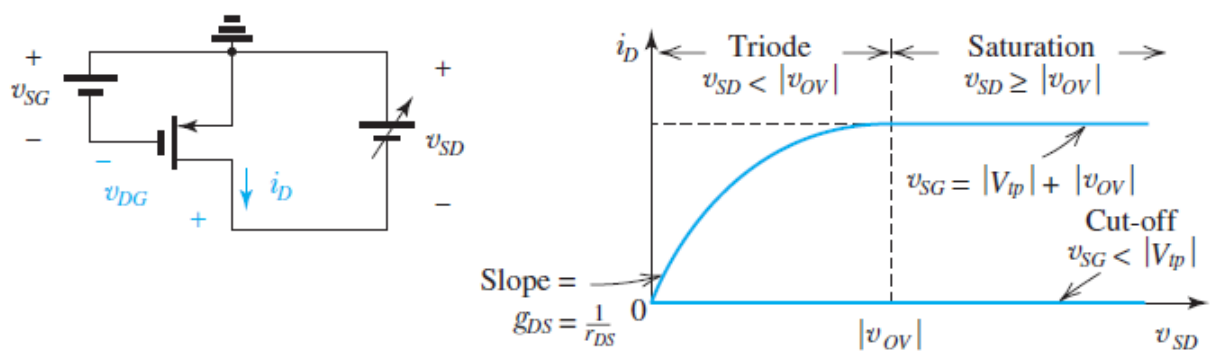

- $v_{SG} < |V_{tp}|$: no channel; transistor in cut-off; $i_D = 0$
- $v_{SG} = |V_{tp}| + |v_{OV}|$: a channel is induced; transistor operates in the triode region or in the saturation region depending on whether the channel is continuous or pinched-off at the drain end;

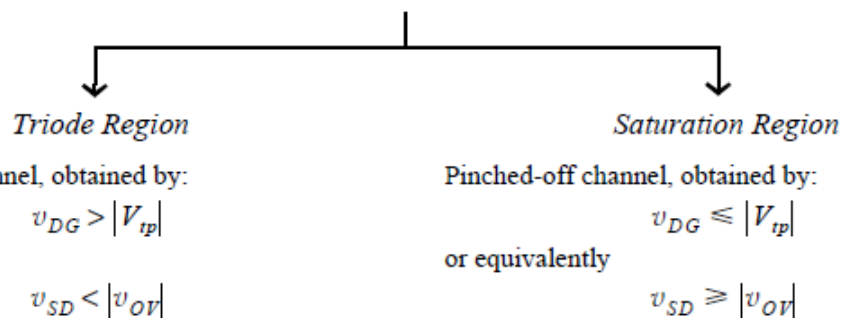

To recap, to turn a PMOS transistor on, the gate voltage has to be made lower than that of the source by at least $|V_{tp}|$. To operate in the triode region, the drain voltage has to exceed that of the gate by at least $|V_{tp}|$; otherwise, the PMOS operates in saturation.

Metal oxide Semiconductor Field effect transistor: Basic structure, working of p channel MOSFET Enhancement type and study of output and transfer characteristics.

TRANSFER CHARACTERISTICS and OUTPUT CHARACTERISTICS CURVE for PMOS-E type MOSFET:

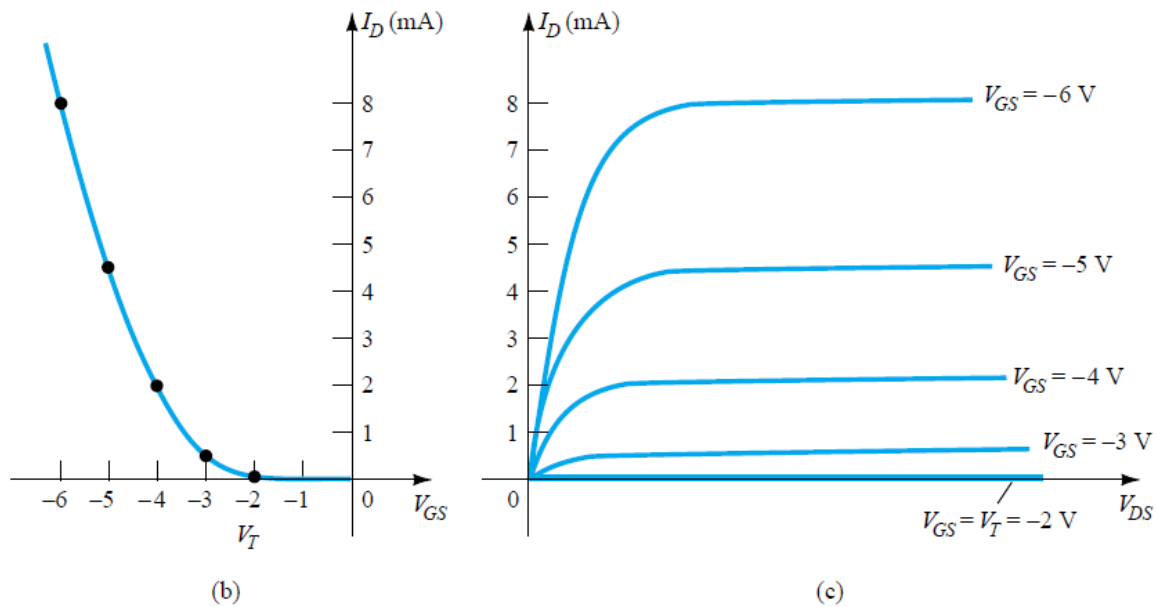

Figure 5.37 p-Channel enhancement-type MOSFET with $V_T = 2 \text{ V}$ and $k = 0.5 \times 10^{-3} \text{ A/V}^2$.

5.2.5 Characteristics of the p-Channel MOSFET

The circuit symbol for the p-channel enhancement-type MOSFET is shown in Fig. 5.19(a). Figure 5.19(b) shows a modified circuit symbol in which an arrowhead pointing in the normal direction of current flow is included on the source terminal. For the case where the source is connected to the substrate, the simplified symbol of Fig. 5.19(c) is usually used.

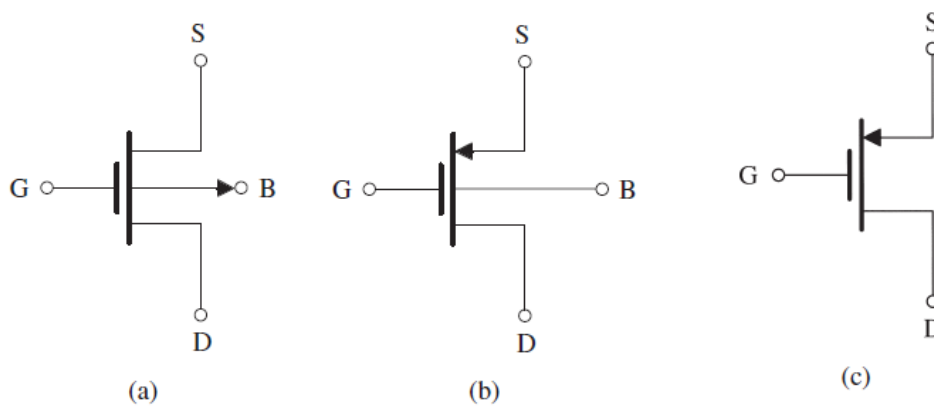

Figure 5.19 (a) Circuit symbol for the p-channel enhancement-type MOSFET. (b) Modified symbol with an arrowhead on the source lead. (c) Simplified circuit symbol for the case where the source is connected to the body.