

Fabrication Processes



- ❑ Wafer Processing & Preparation
- ❑ Oxidation
- ❑ Epitaxy
- ❑ Diffusion
- ❑ Ion Implantation
- ❑ Lithography
- ❑ Etching
- ❑ Metallization
- ❑ CMOS Process Flow for N-well, P-well & Twin Tub

Fabrication Steps :

- Refining of Si
- Crystal growth and wafer preparation
- Epitaxy
- Deposition
- Oxidation
- Diffusion
- Ion Implantation
- Lithography
- Etching
- Metallization

CMOS Inverter Fabrication :

- N-well process
- P-well process
- Twin tub process

CMOS Inverter using N-well Process:

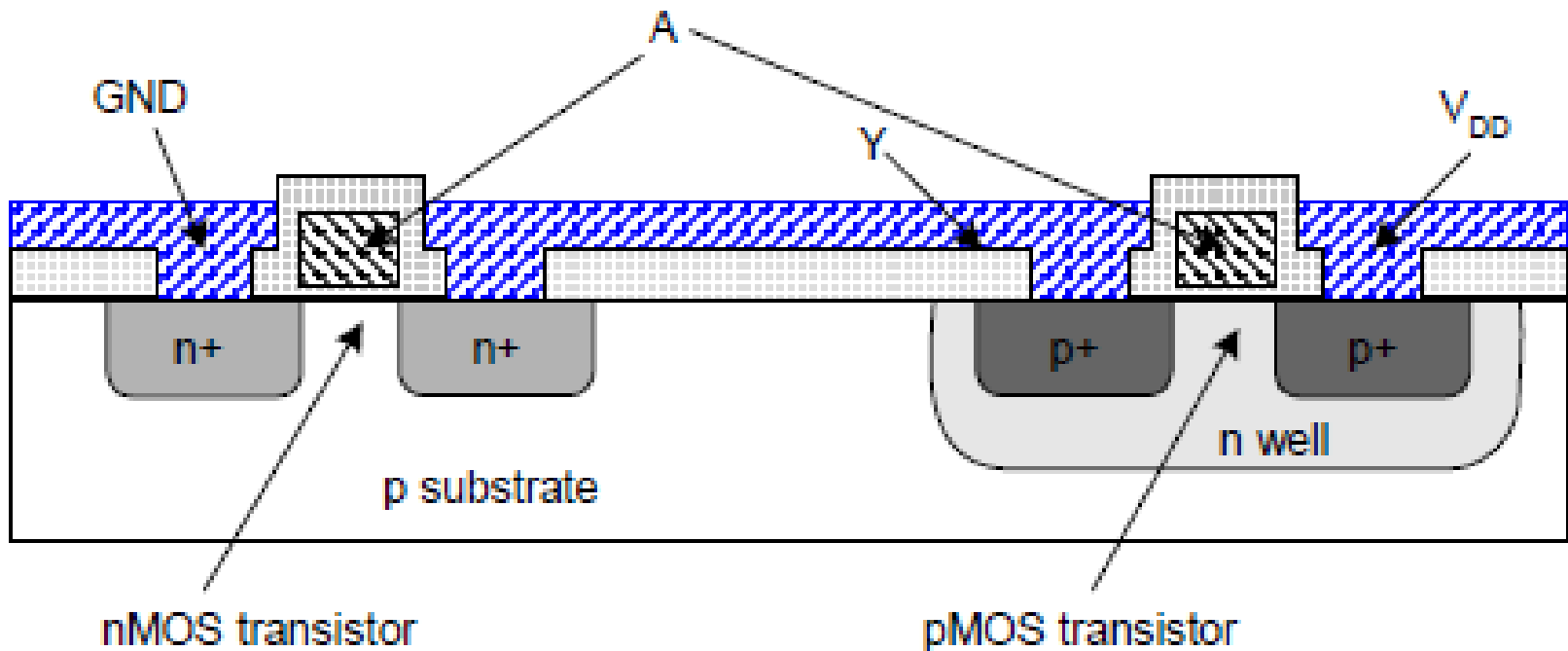

CMOS Inverter using P-well Process:

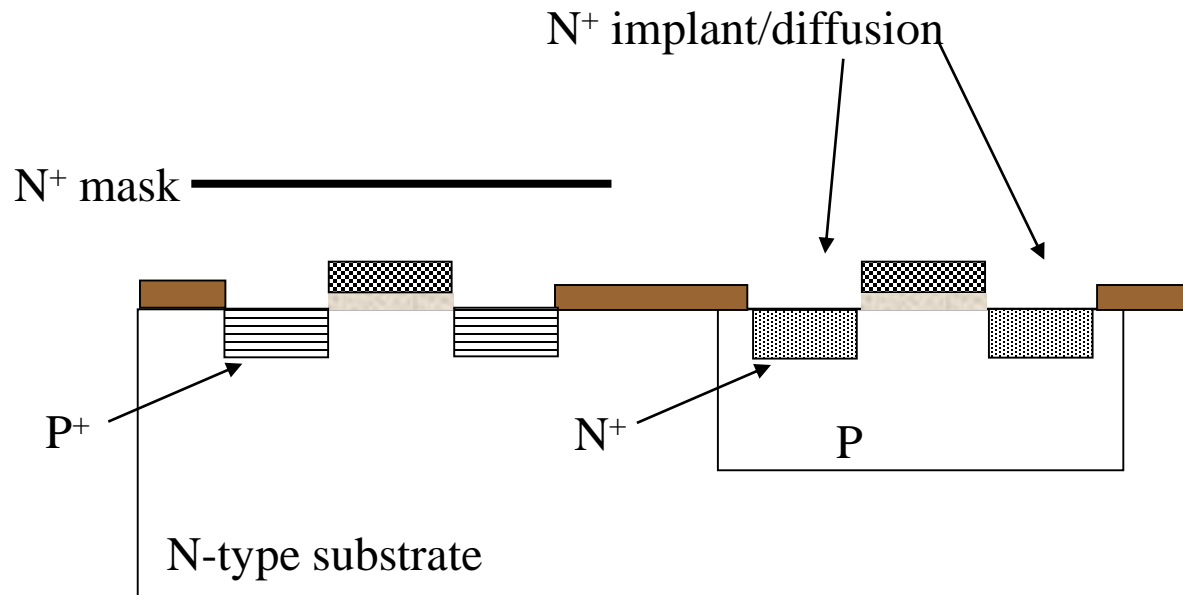

CMOS Inverter using Twin-Tub Process:

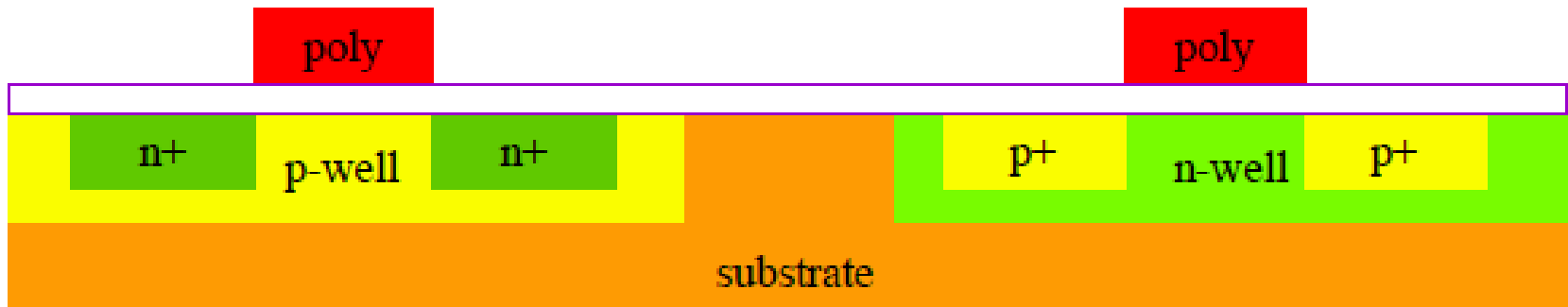

CMOS Inverter using N-well Process:

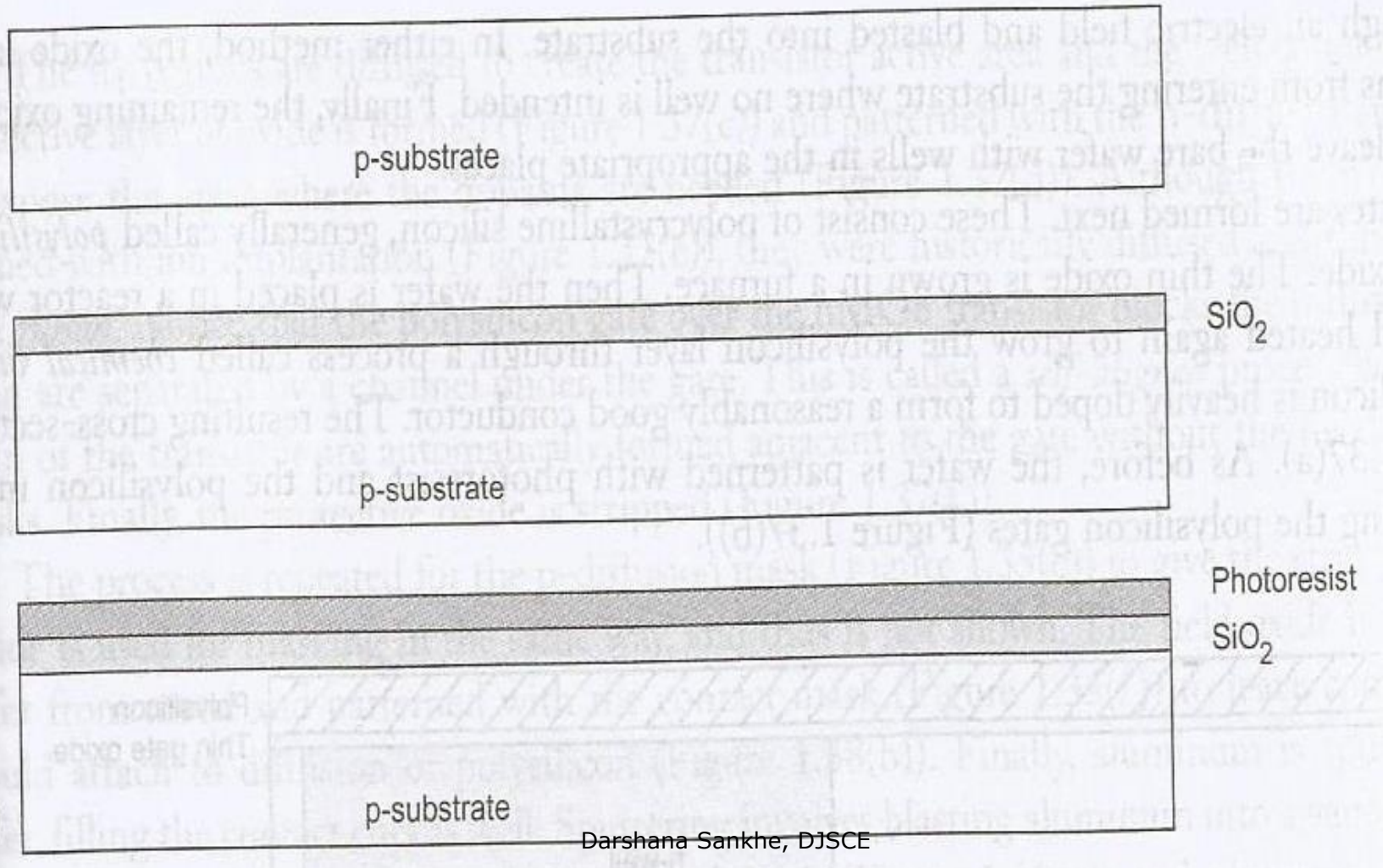

CMOS Inverter using N-well Process:

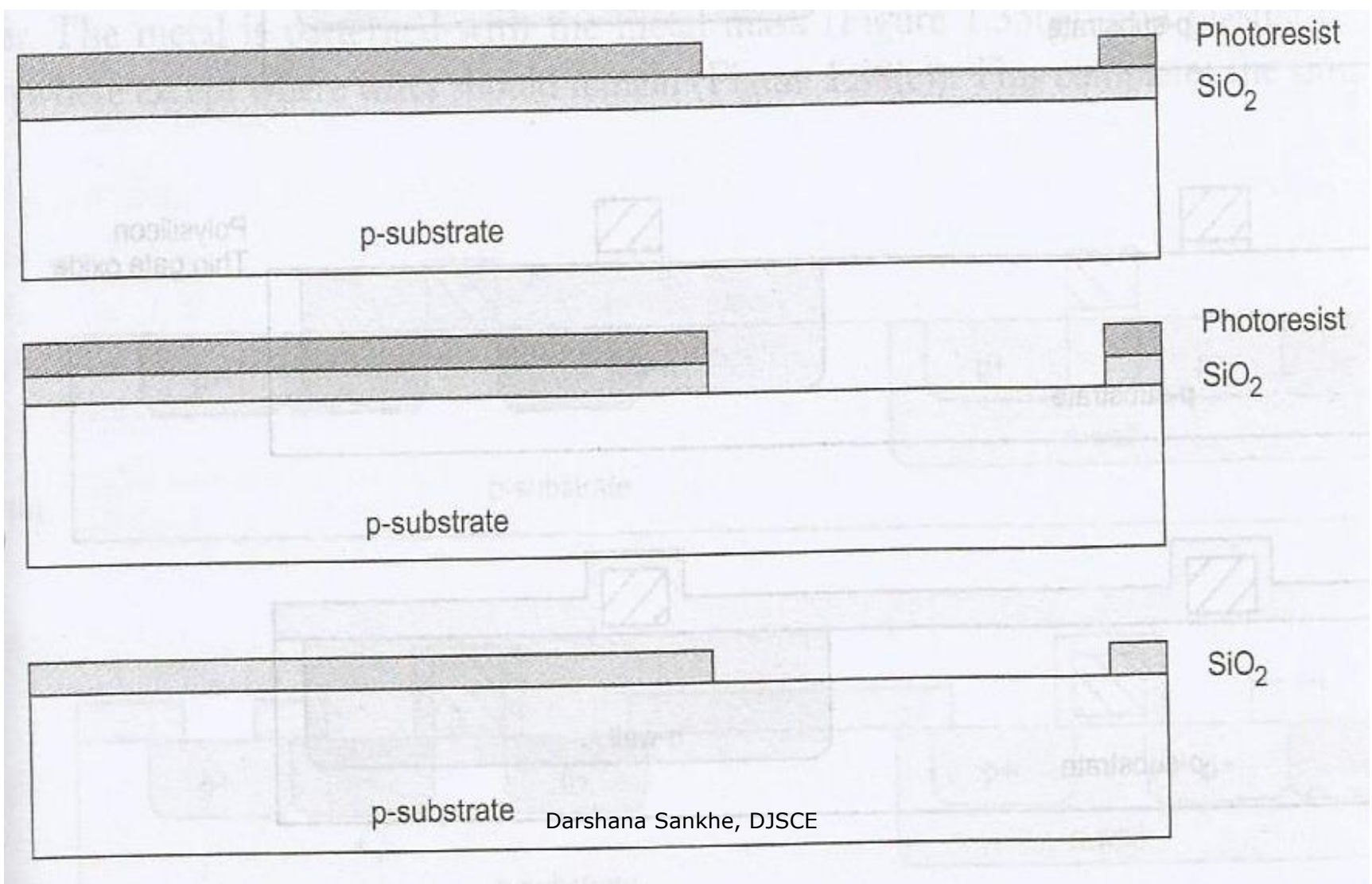

CMOS Inverter using N-well Process:

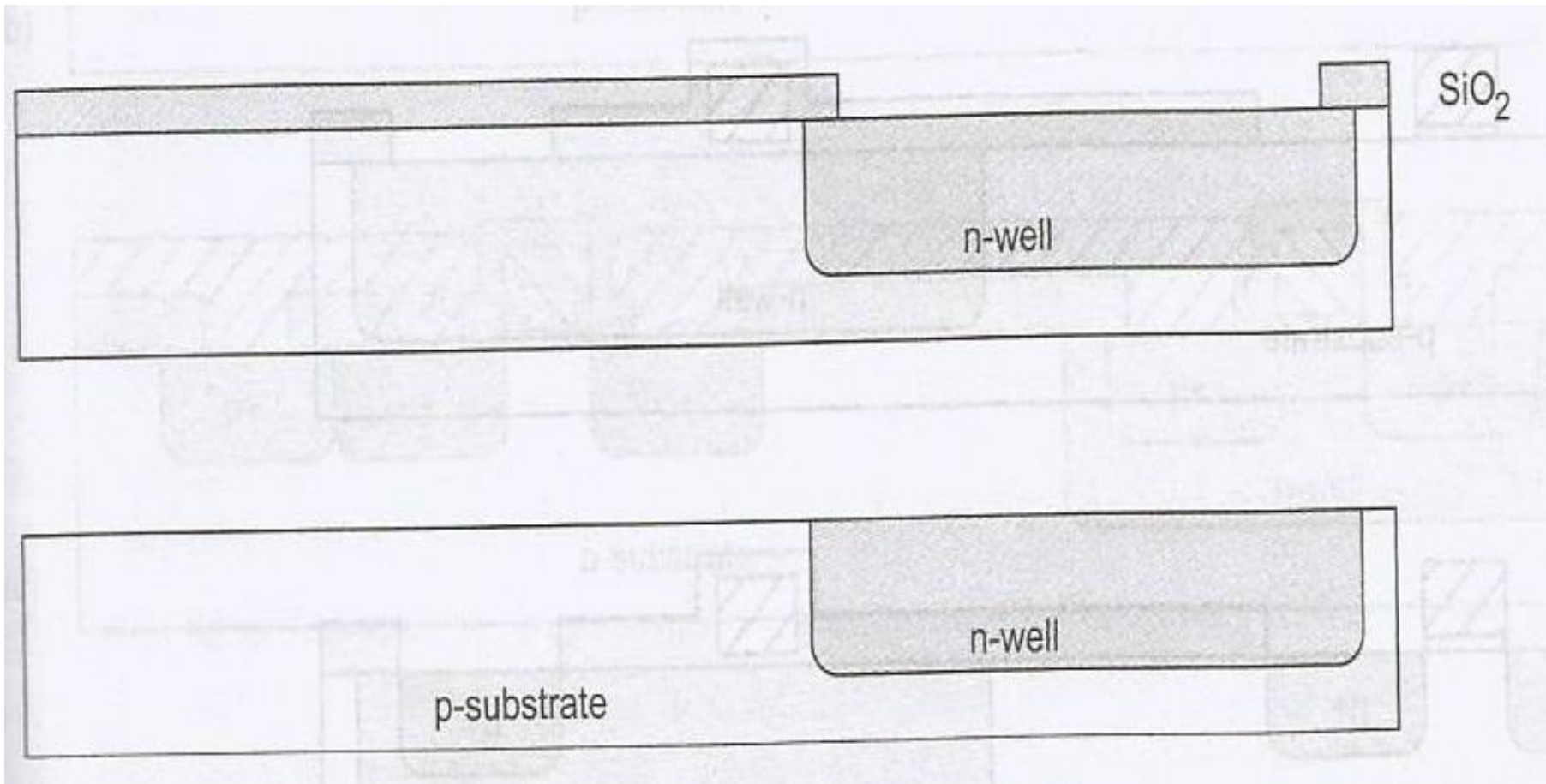

CMOS Inverter using N-well Process:

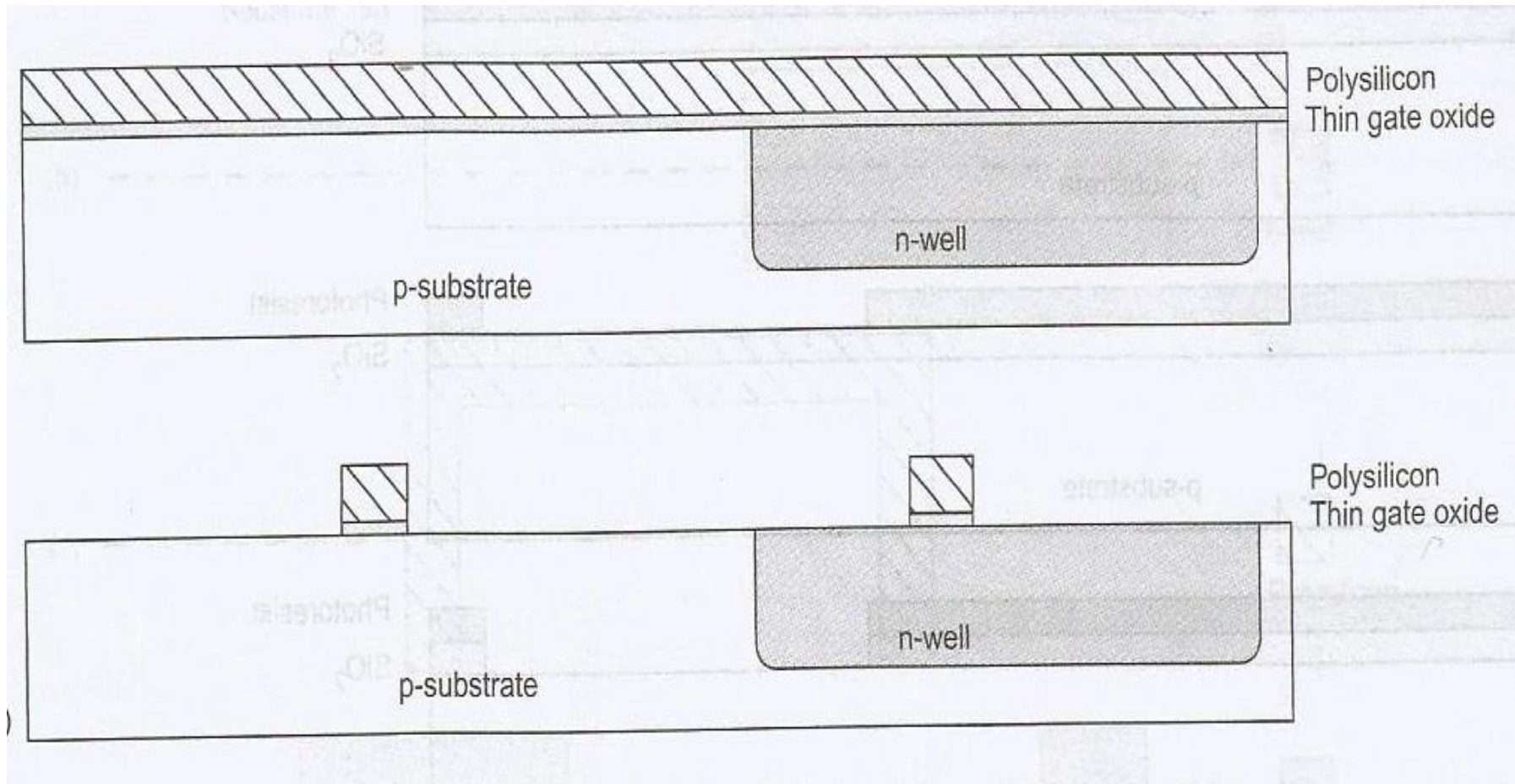

CMOS Inverter using N-well Process:

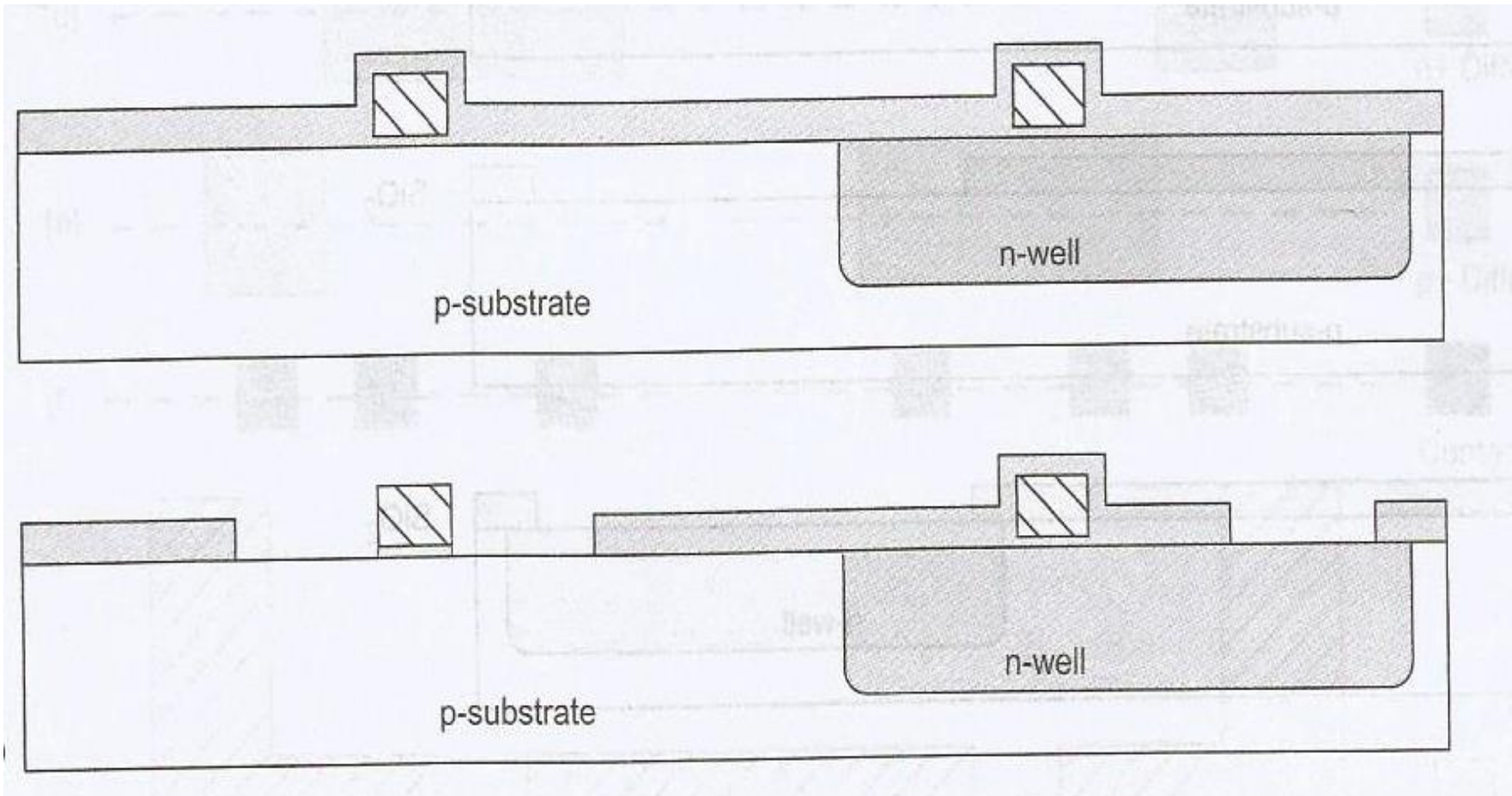

CMOS Inverter using N-well Process:

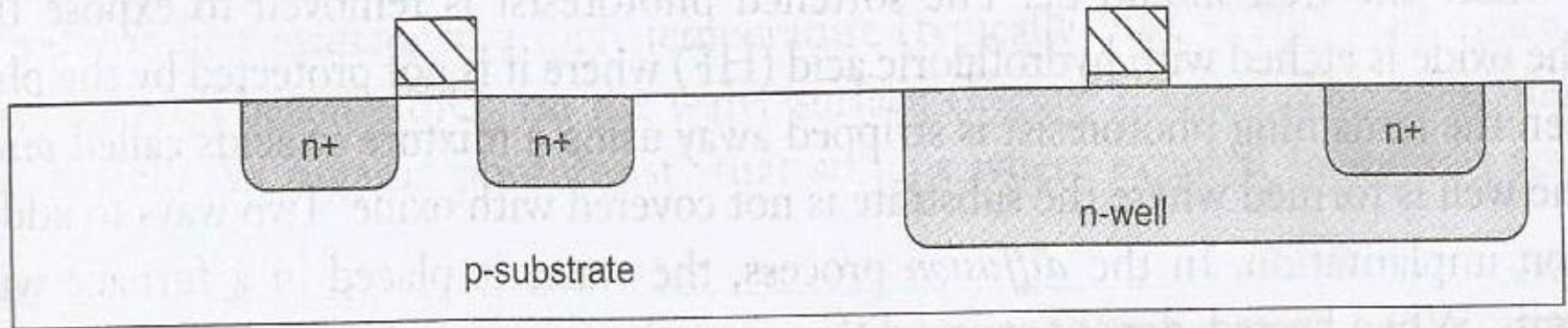
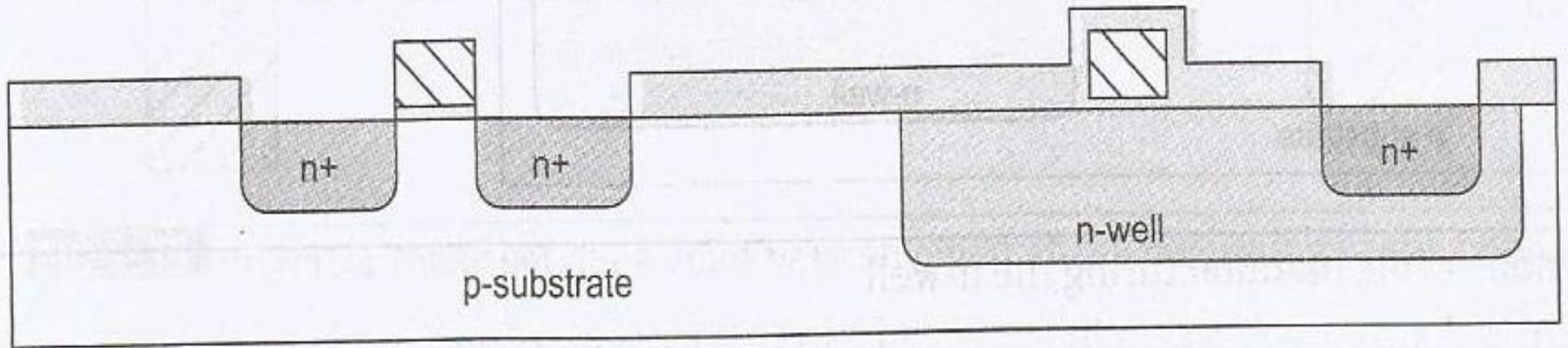

CMOS Inverter using N-well Process:

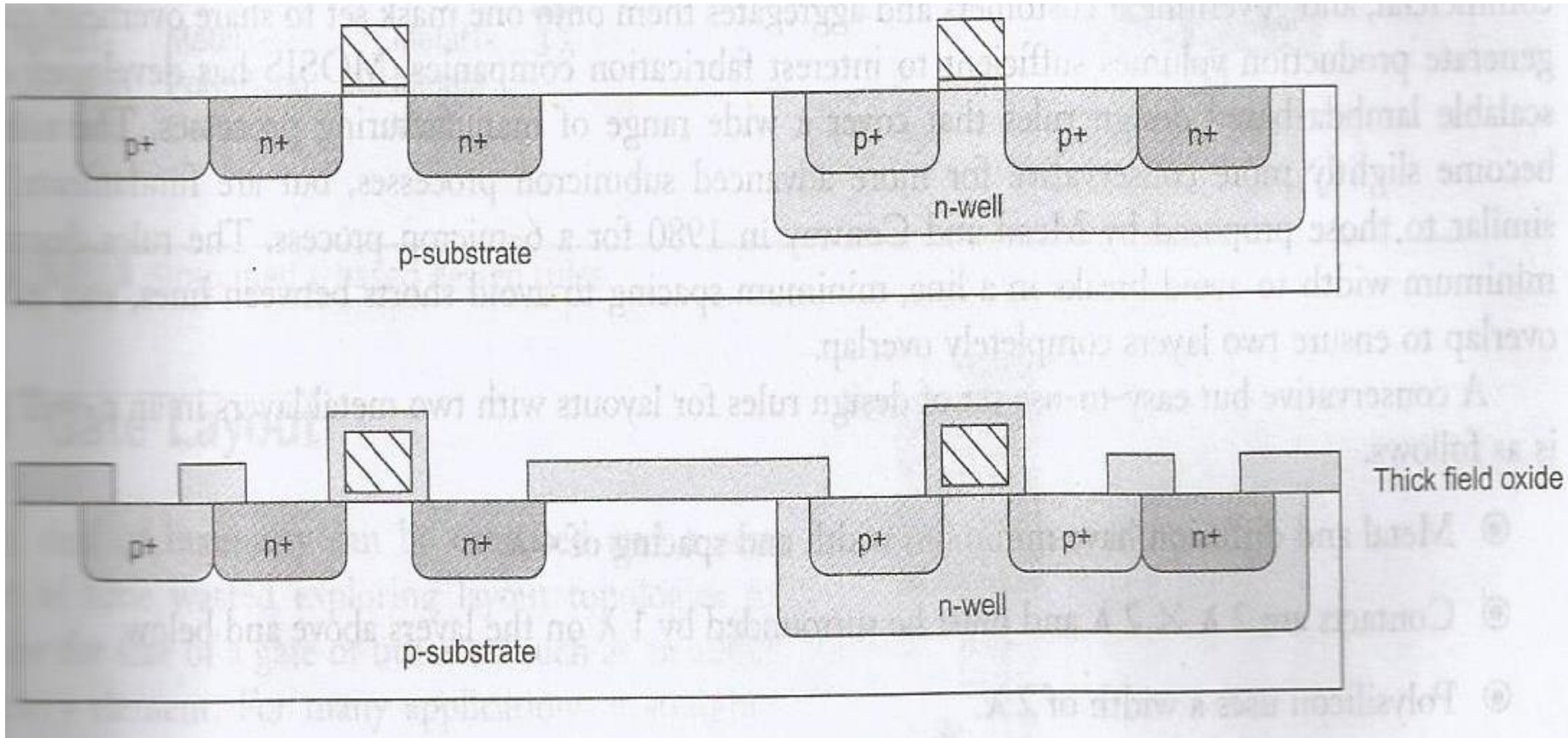

CMOS Inverter using N-well Process:

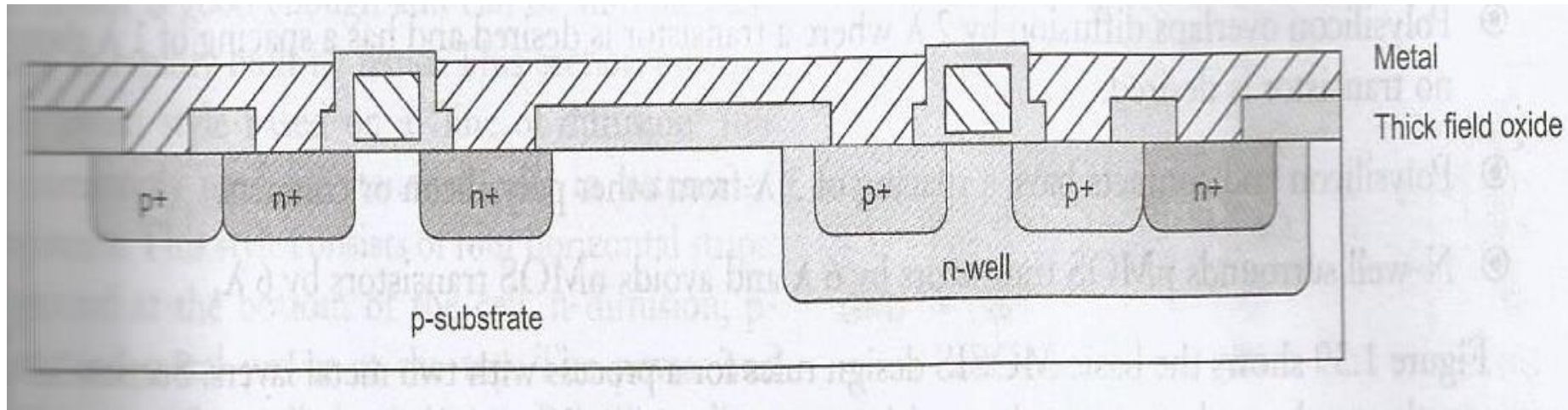

CMOS Inverter using P-well Process:

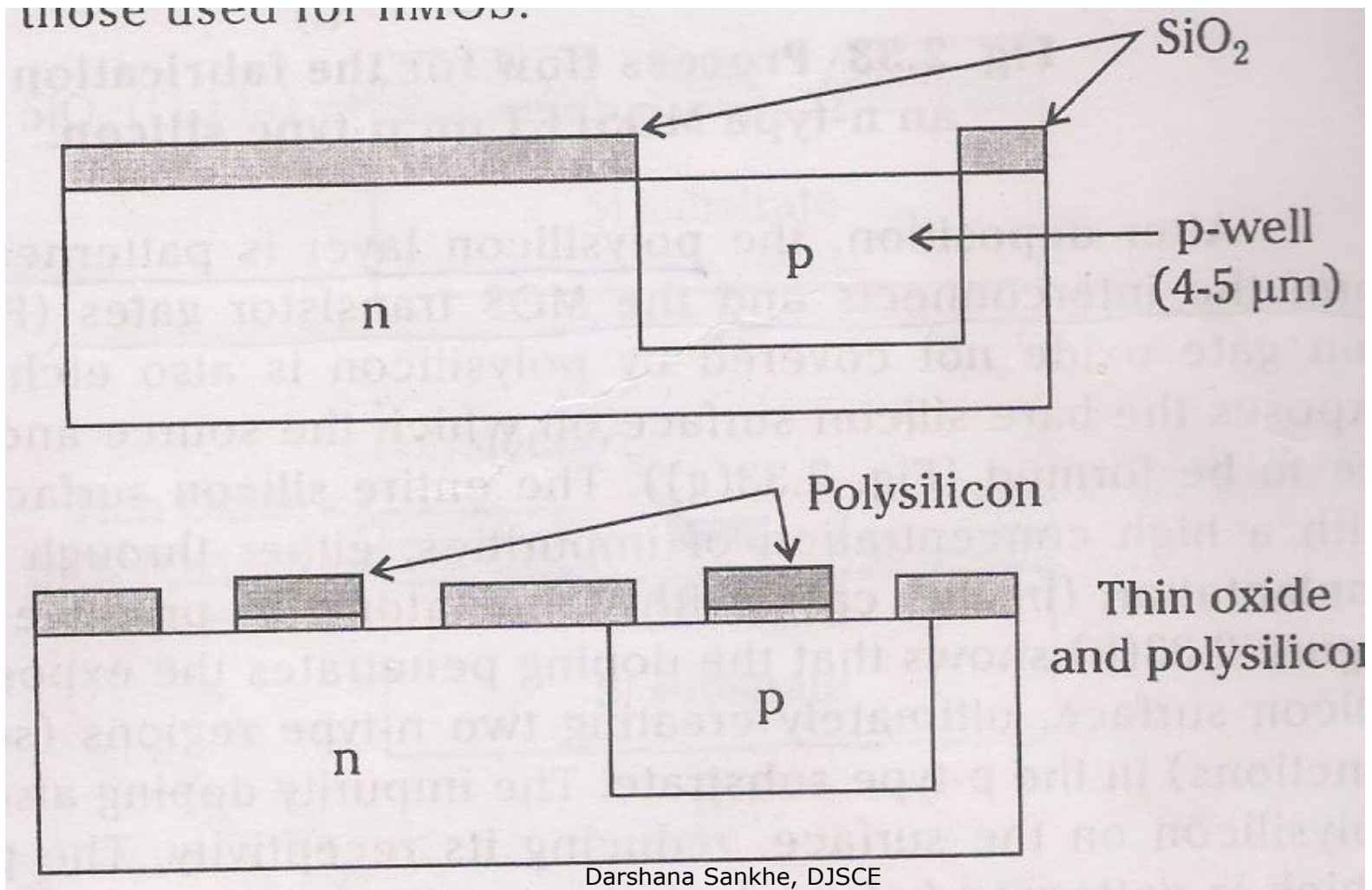

CMOS Inverter using P-well Process:

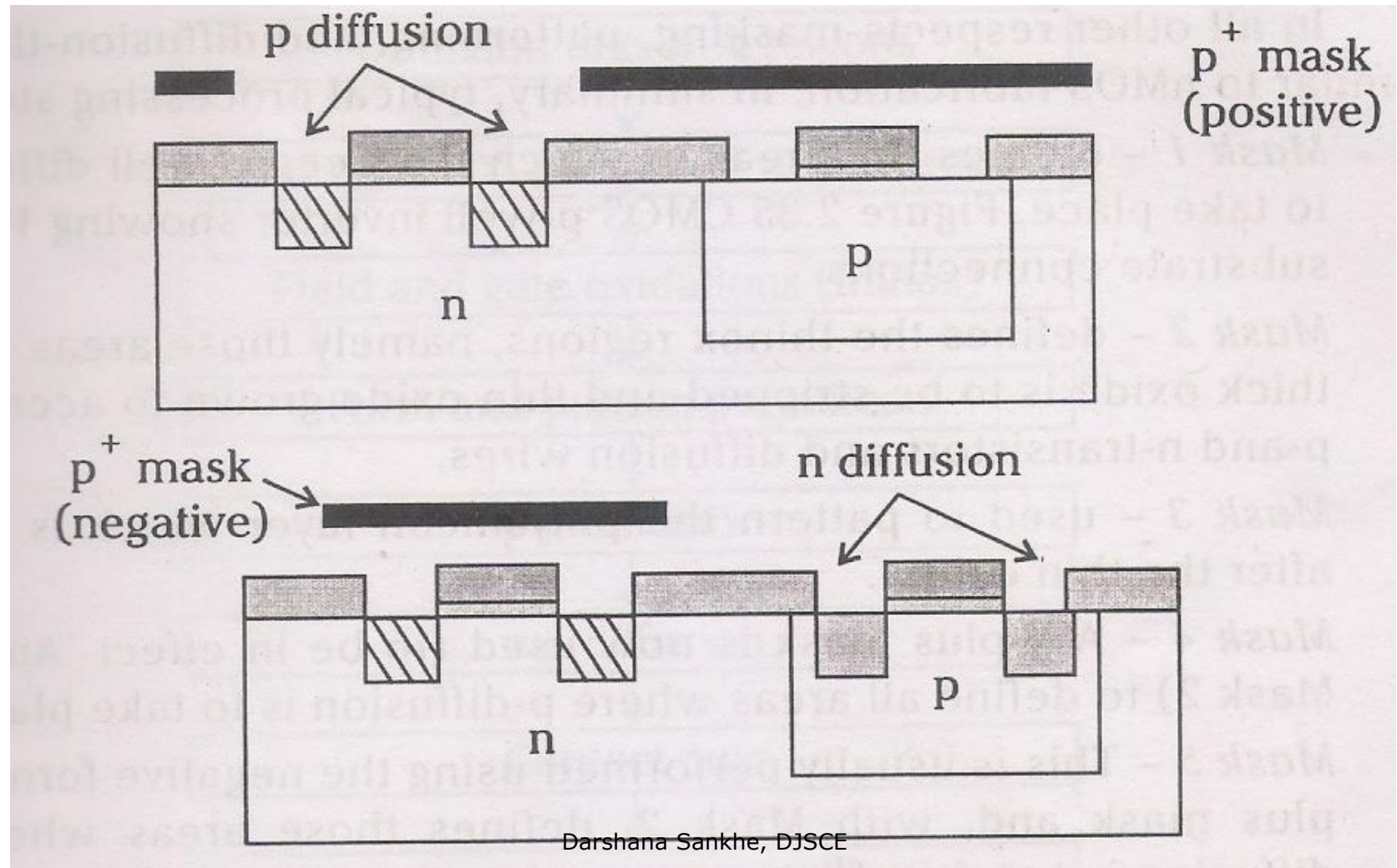

CMOS P-well INVERTER:

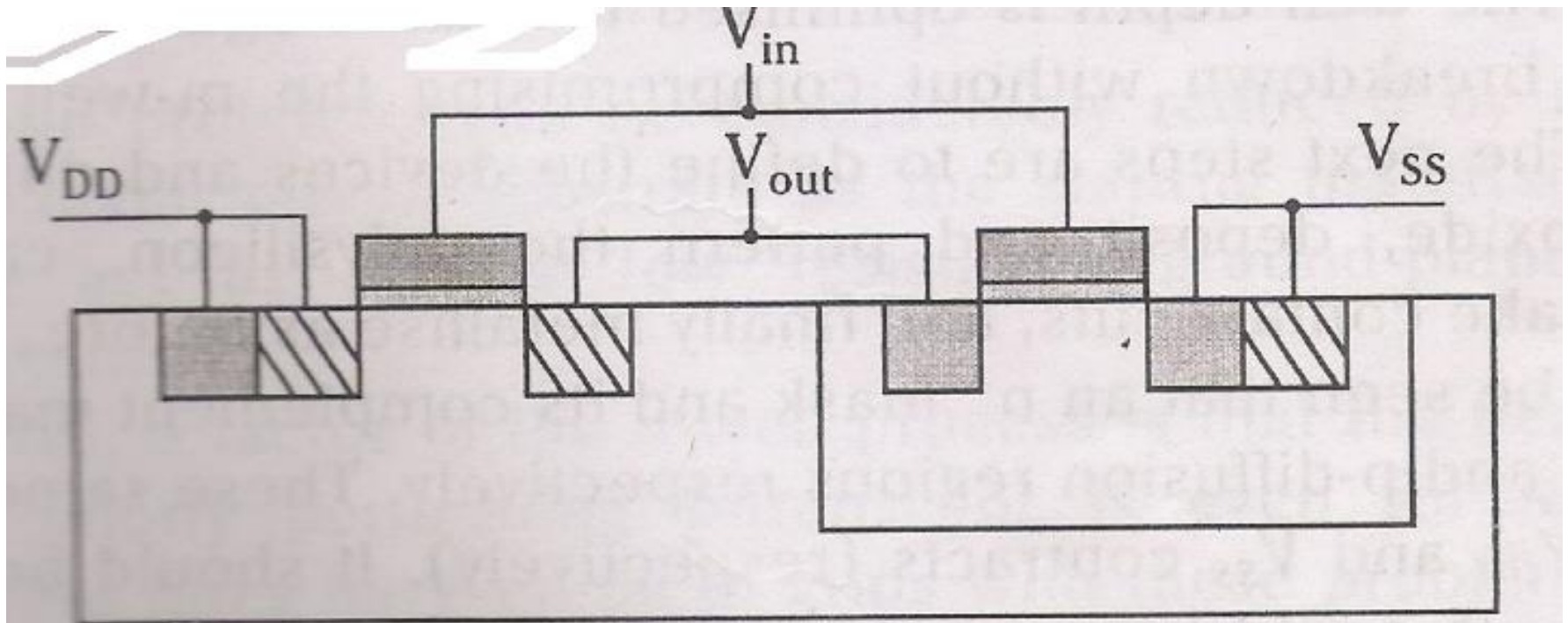
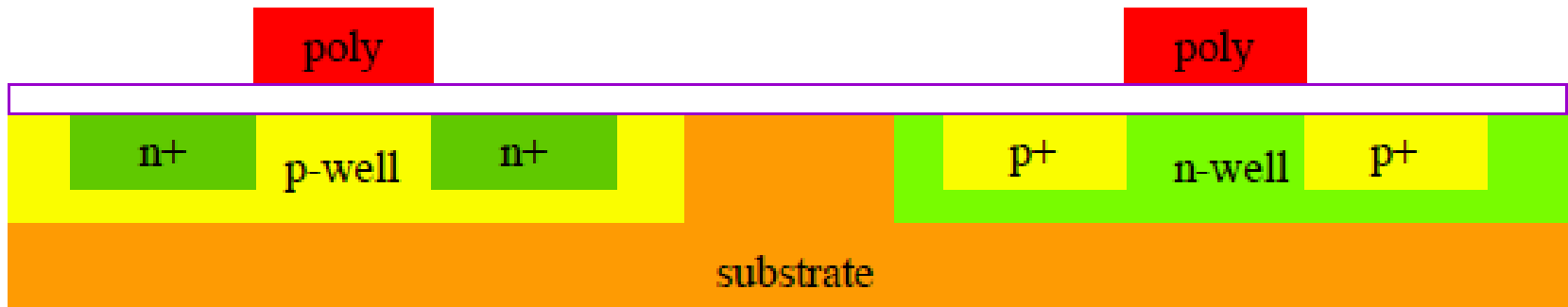

Fig. 2.35 CMOS p-well inverter showing V_{DD} and V_{SS} substrate connections.

CMOS Fabrication Mask :

1. Define window in oxide region/ well mask
2. Pattern poly mask
- 3,4. Diffusion mask(n-diffusion & p-diffusion)
5. Contact cut mask
6. Metal layer pattern
7. Over glass layer mask for bonding pads

CMOS Inverter using Twin-Tub Process:



CMOS Inverter using Twin-Tub Process:

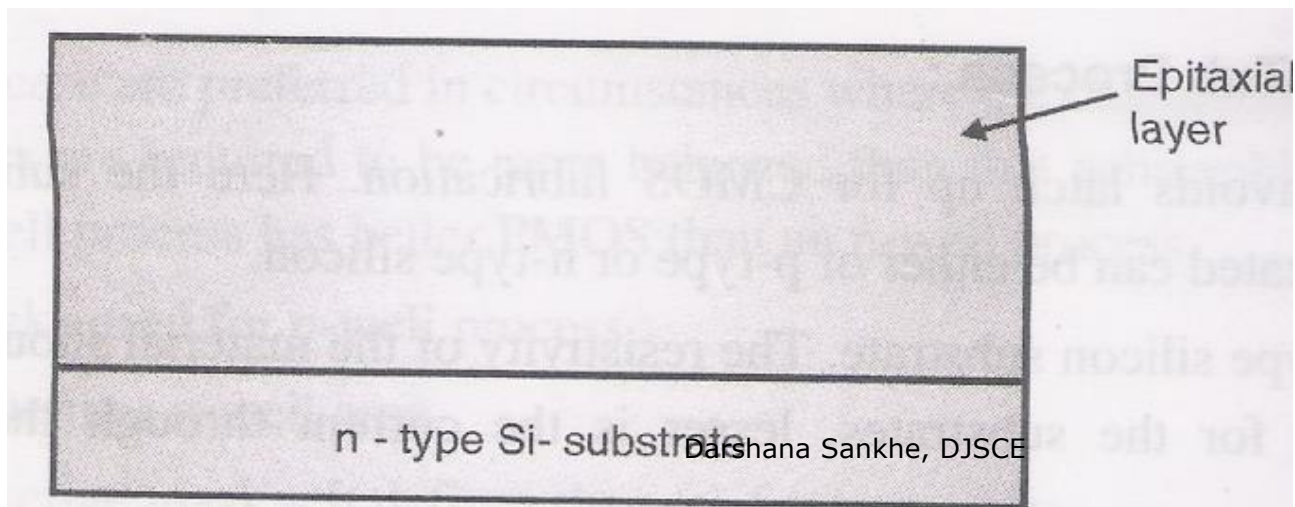
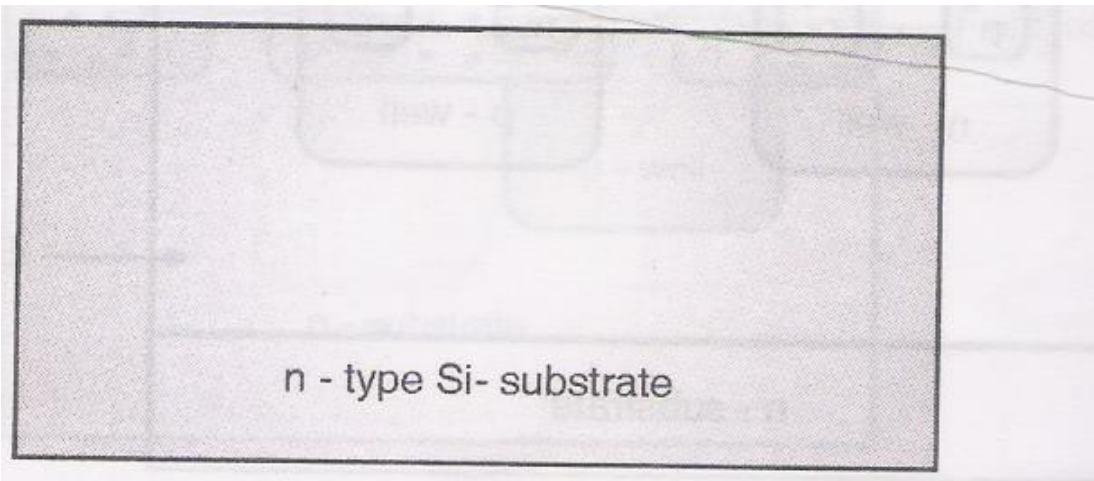

CMOS Inverter using Twin-Tub Process:

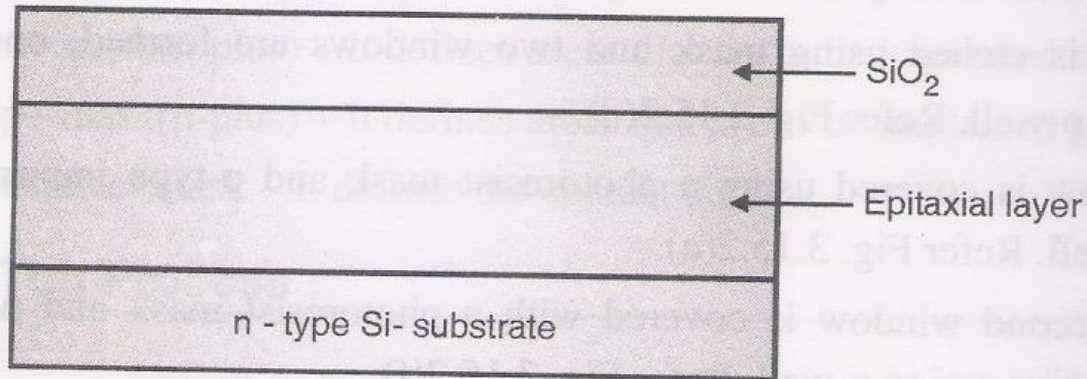

(c)

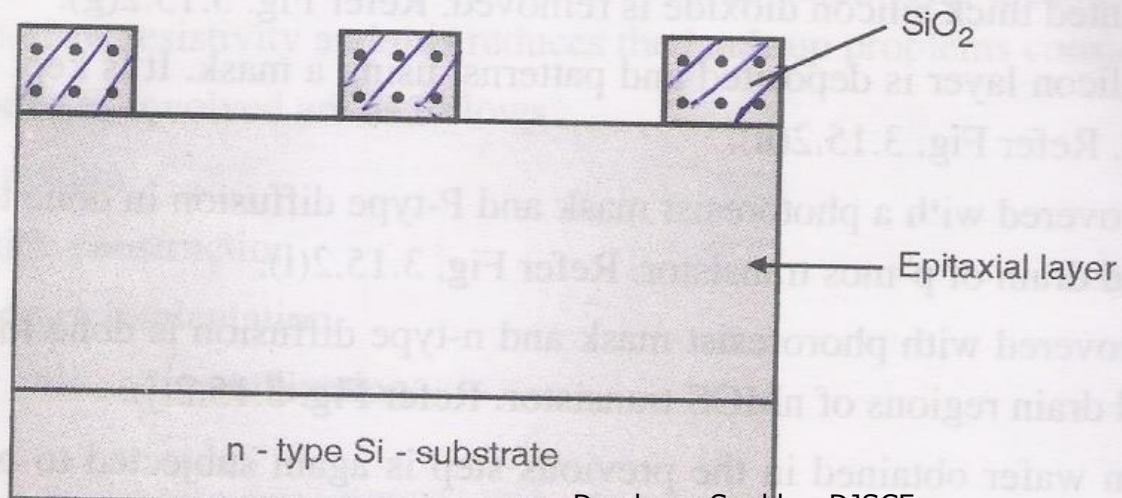

CMOS Inverter using Twin-Tub Process:

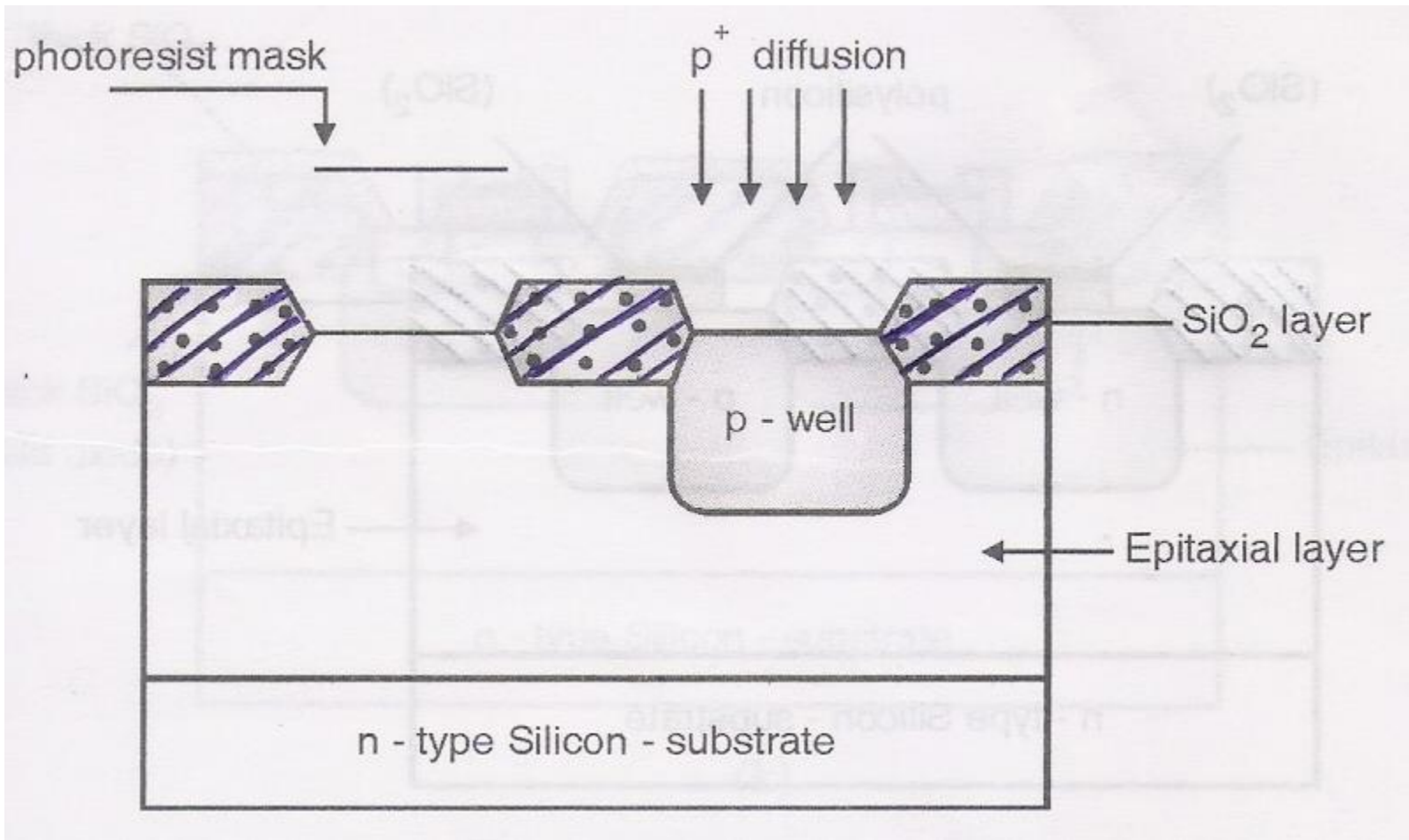

CMOS Inverter using Twin-Tub Process:

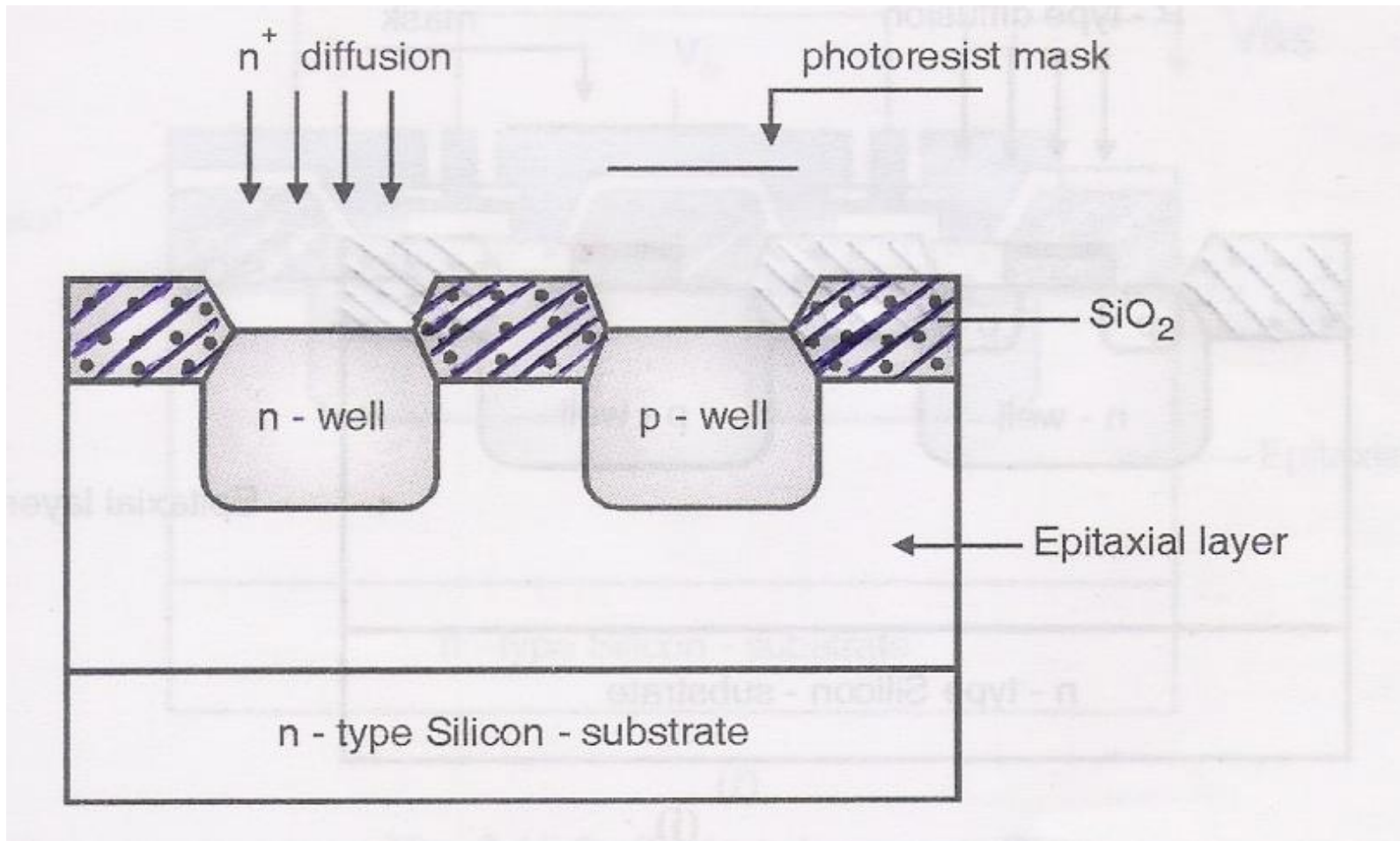

CMOS Inverter using Twin-Tub Process:

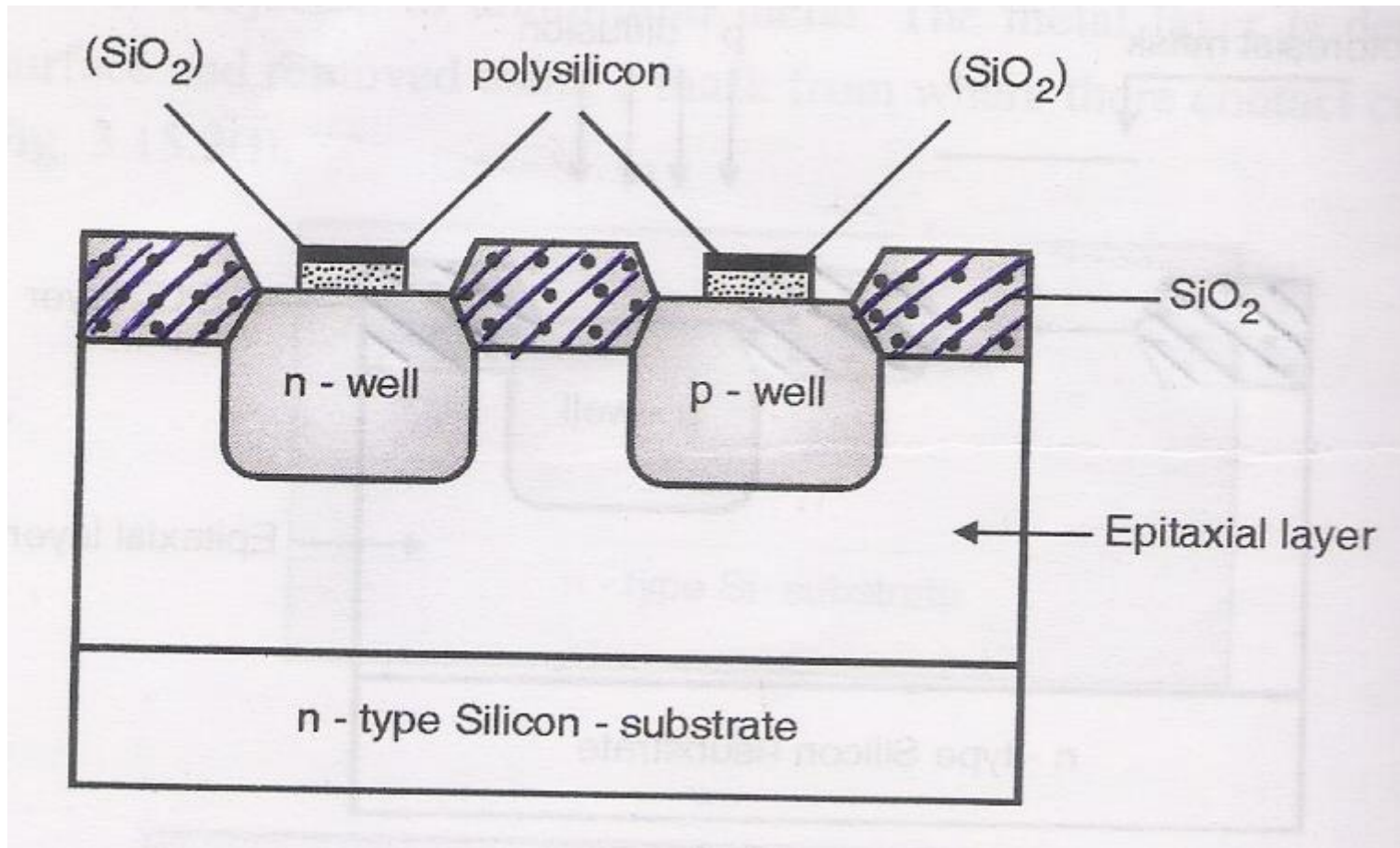

CMOS Inverter using Twin-Tub Process:

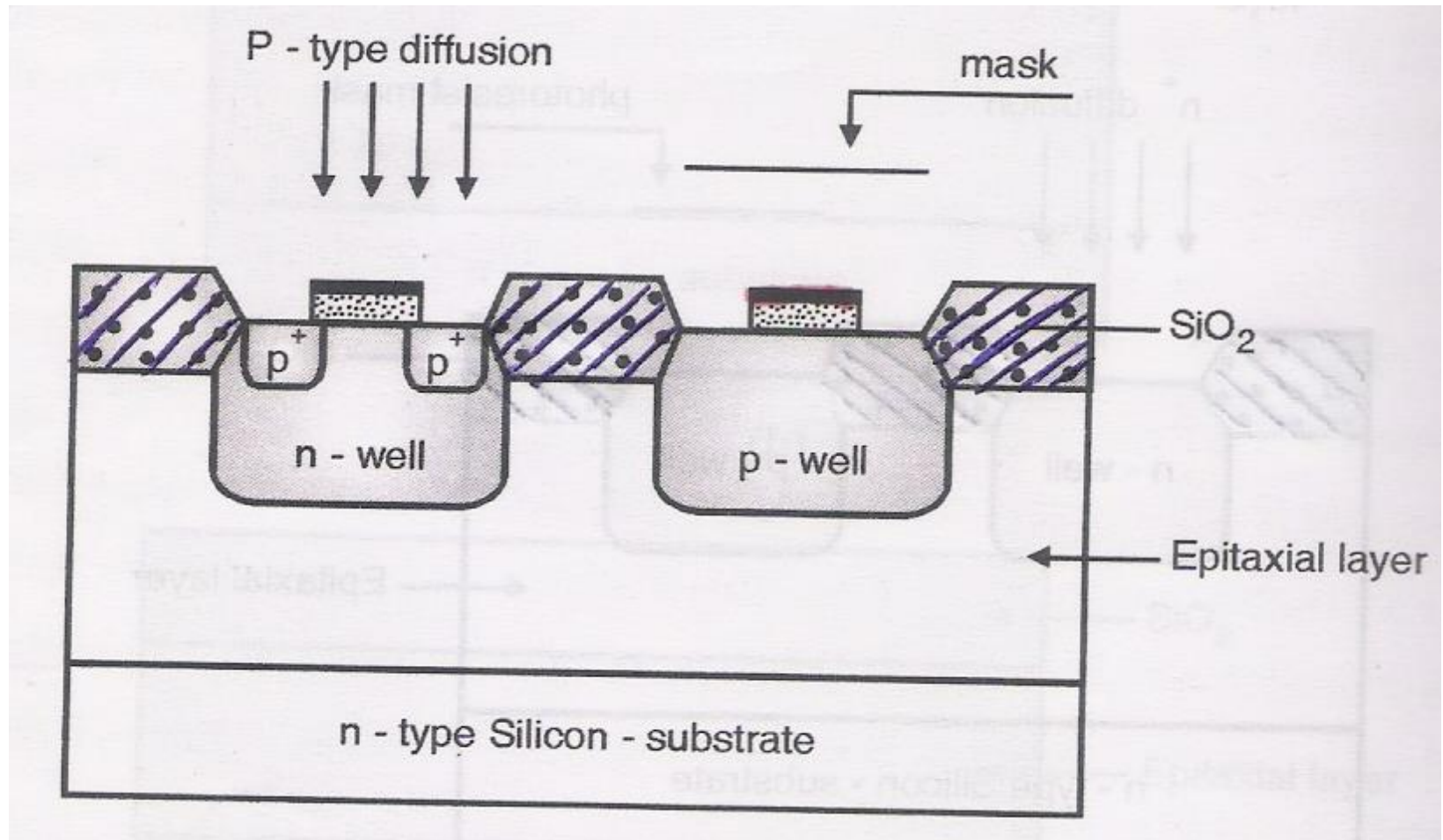

CMOS Inverter using Twin-Tub Process:

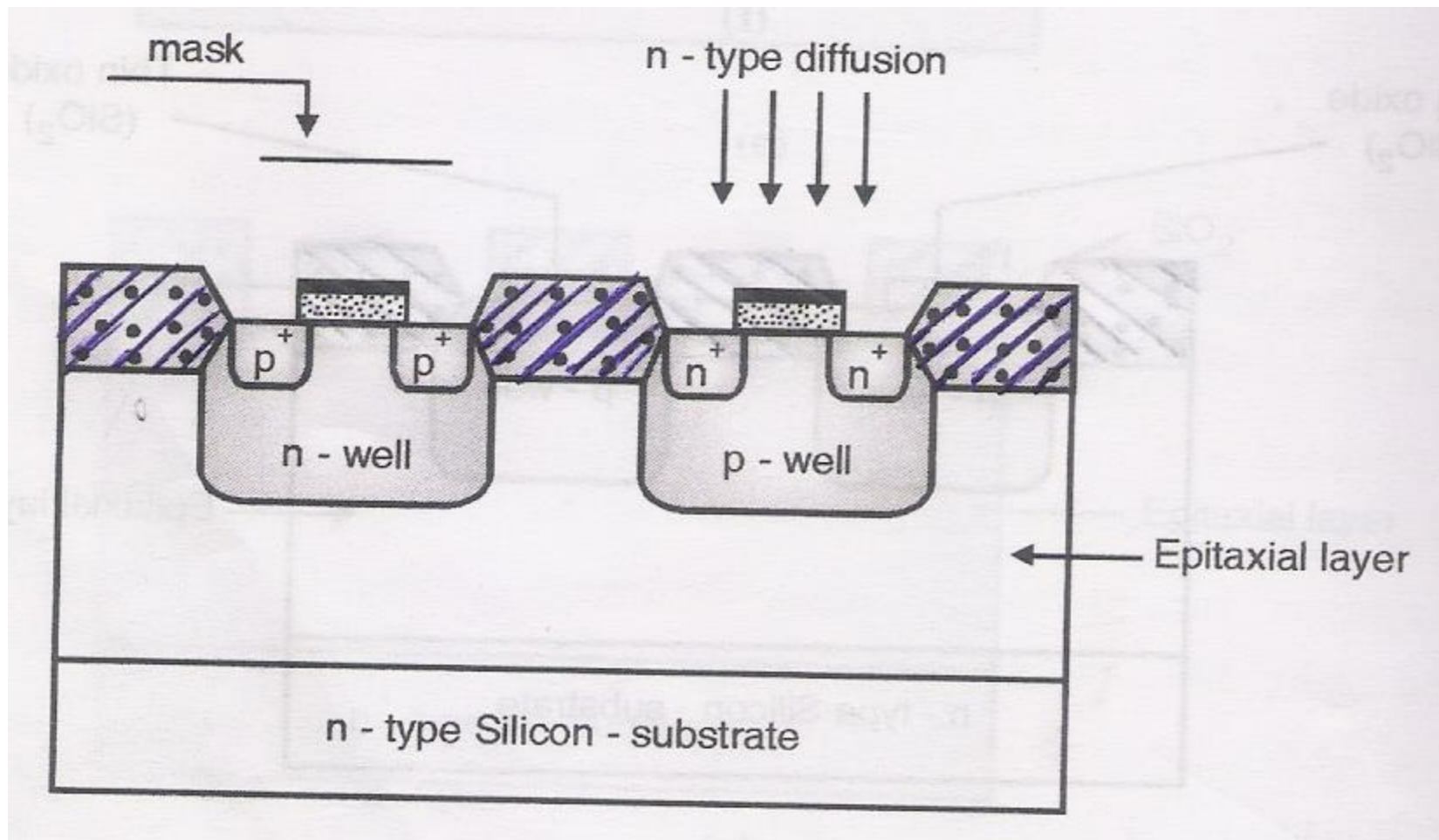

CMOS Inverter using Twin-Tub Process:

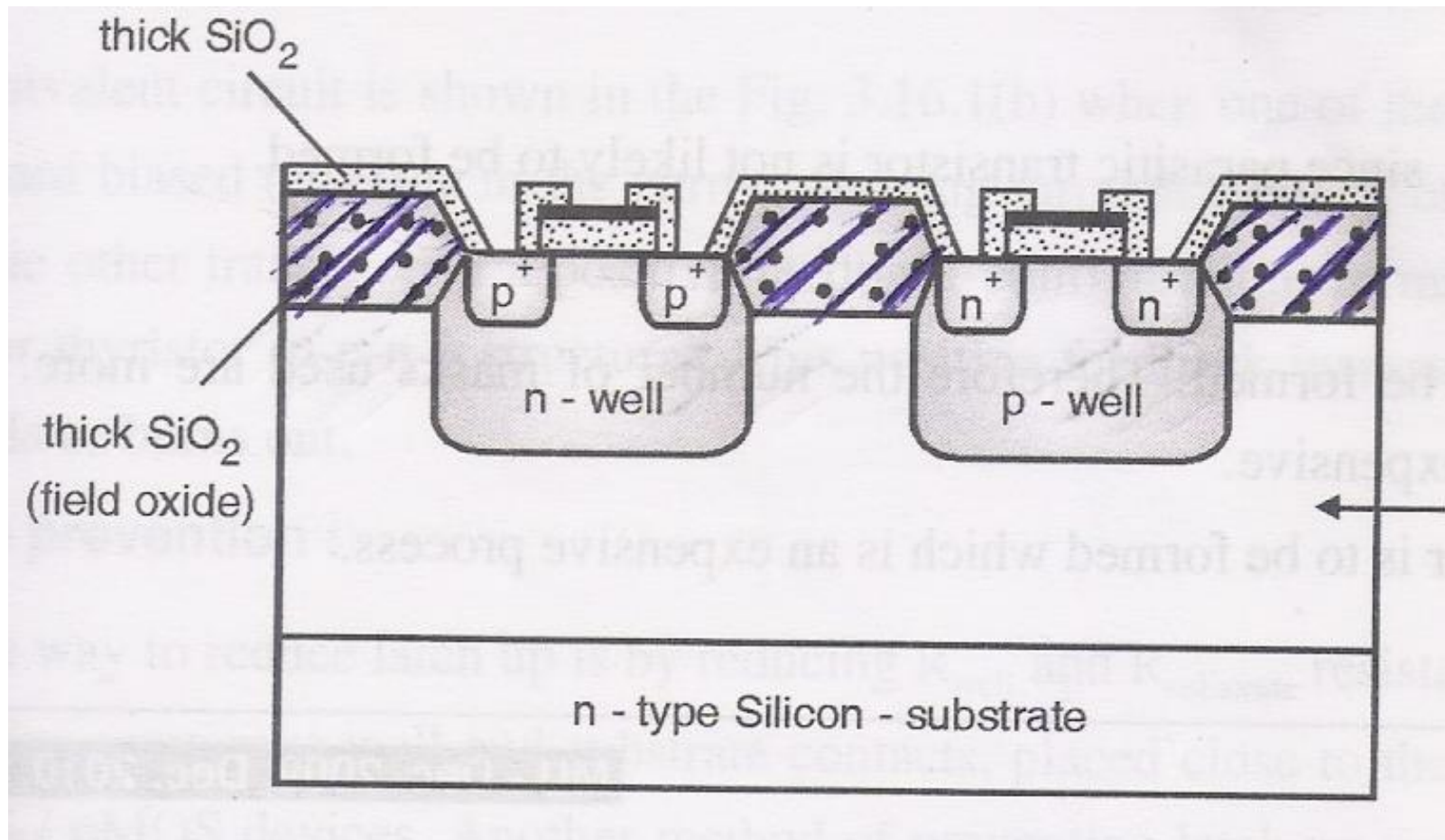

CMOS Inverter using Twin-Tub Process:

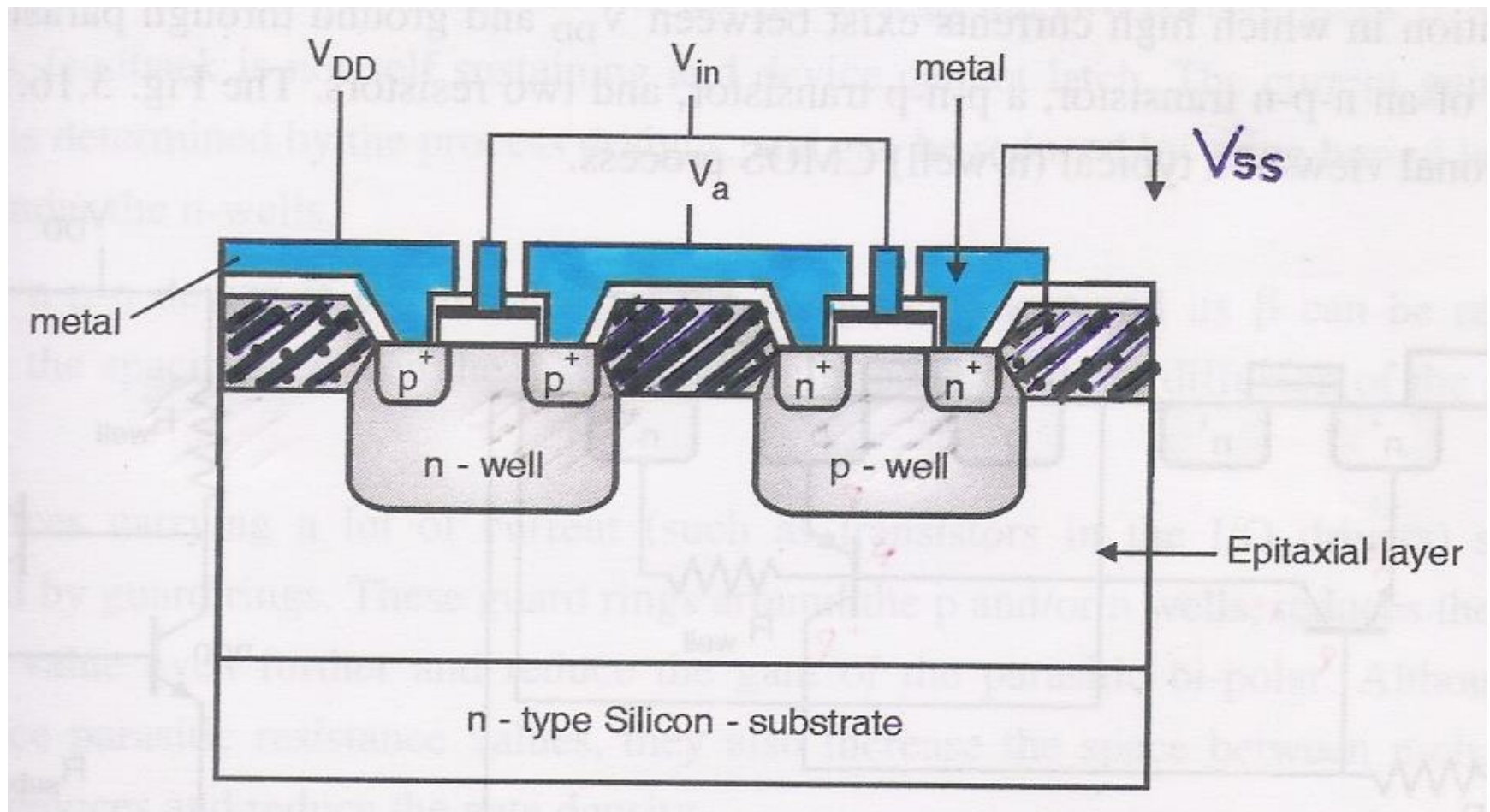

Thank You

